



On the use of flat tile armour in high heat flux components

M. Merola^{*}, G. Vieider

The NET Team, Boltzmannstr. 2, 85748 Garching bei Muenchen, Germany

Abstract

The possibility to have a flat tile geometry for those high heat flux components subjected to a convective heat flux (namely the divertor dump target, lower vertical target, and the limiter) has been investigated. Because of the glancing incidence of the power load, if an armour tile falls off an extremely high heat flux hits the leading edge of the adjacent tile. As a result a rapid temperature increase occurs in the armour–heat sink joint. The heat flux to the water coolant also increases rapidly up to a factor of 1.7 and 2.3 for a beryllium and CFC armour, respectively, thus causing possible critical heat flux problems. Thermal stresses in the armour–heat sink joint double in less than 0.4 s and triplicate after 1 s thus leading to a possible cascade failure. Therefore the use of a flat tile geometry for these components does not seem to be appropriate. In this case a monoblock geometry gives a much more robust solution. © 1998 Elsevier Science B.V. All rights reserved.

1. Introduction

The development of a suitable technology to manufacture high heat flux components (namely divertor, baffle and limiter) is a critical issue in the ITER design. The solutions proposed so far can be classified into two distinct categories: monoblock and flat tile. In the monoblock geometry a round hole is obtained in each armour tile by drilling. Then the cooling tube is inserted and joined to the armour. The flat tile geometry consists in a copper alloy heat sink with a rectangular external cross section. Armour flat tiles are then joined onto the plasma facing surface. The cooling channel can be either round or rectangular.

Several thermal fatigue tests as well as an extensive numerical analysis have been carried out by the EU Home Team aimed at assessing the “fitness for purpose” of various proposed technologies [1].

Among the European small scale mock-ups with a beryllium (Be) flat tile armour, the best results showed a fatigue limit in excess of 5 MW/m² (CuMnSn brazed solution). As far as the mock-ups with a CFC flat tile armour are concerned, the fatigue limit was in excess of 18 MW/m² for an Active Metal Casting (AMC®) joint

and a 3D carbon fibre reinforced carbon (CFC). Tungsten flat tile mock-ups manufactured by metal casting showed a failure limit of 16 MW/m².

No damage developed in CFC monoblocks after thermal fatigue cycling at 24 MW/m². This excellent result can be explained by the much lower thermal cycling stress developed in a CFC monoblock with respect to that generated in the flat tile – heat sink interface. A promising Be monoblock was also manufactured. However the experimental results need to be confirmed since a silver-based braze (InCuSil) was used and because the surface melting prevented an extended testing at 21 MW/m².

The above fatigue results must be compared with the following design requirements:

- divertor dump target and lower vertical target: nominal pulses at 5–10 MW/m² and off-normal transients up to 20 MW/m² [2];
- local limiters with pulses up to 15 MW/m² [3];
- divertor upper vertical target, dome and baffle with nominal pulses up to 3–5 MW/m².

Furthermore in the case of a convective heat flux as for the divertor dump target and lower vertical target, and for the limiter, if a flat tile geometry is envisaged, one should also take into account that if one tile falls off, the adjacent tile receives an extremely high heat flux localised on its edge as a consequence of the glancing incidence (Fig. 1).

^{*} Corresponding author. Tel.: +49 89 3299 4220; fax: +49 89 3299 4198; e-mail: merolam@ipp.mpg.de.

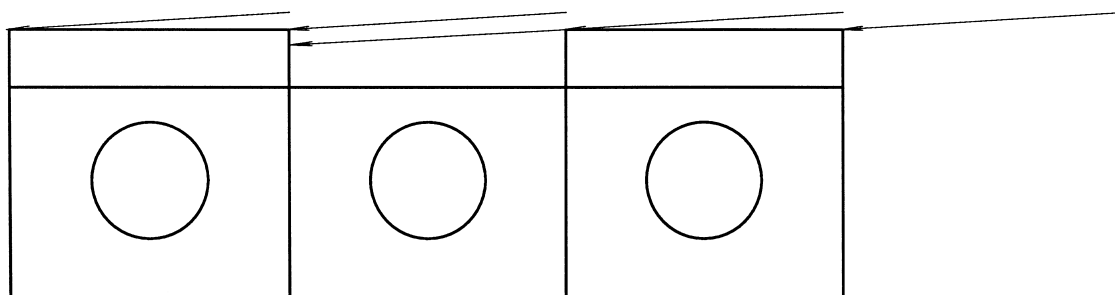

Fig. 1. Sketch of the effect of the glancing incidence of the heat flux on a flat tile geometry after the loss of a tile.

The aim of the present work is to study the possible consequences of this effect to check whether a flat tile geometry can represent a viable solution for the divertor dump target and lower vertical target, and for the limiter.

2. Theoretical model

To study the consequences of the loss of a tile a 2D numerical analysis was carried out by means of the ANSYS finite element code [4]. Fig. 2 shows the geometrical model. Both CFC and Be armour materials were investigated. The orthotropic properties of the SEP NS31 CFC grade were used. The heat sink was a copper alloy (GlidCop®). The conditions for the water coolant were the following: 150°C, 4 MPa, 10 m/s. The heat transfer coefficient vs. wall temperature was computed by means of the EUPITER code [5] which implements the Sieder-Tate, the Bergles-Rohsenow and the Thom-CEA correlations in pure forced convection, at the onset

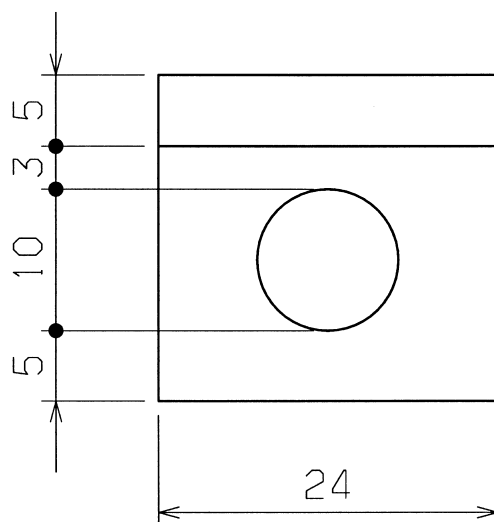

Fig. 2. Geometrical model (dimensions in mm).

of nucleate boiling and in the nucleate boiling regime, respectively. As far as the thermal analysis is concerned, after an initial steady state calculation at 5 MW/m² the loss of one tile was assumed. As a consequence the power load on the missing tile was concentrated on a 1 mm width area on the side surface of the adjacent tile. Therefore the incident heat flux on this area was $24 \times 5 = 120$ MW/m². Because of the high surface temperature reached during the following transient, the cooling due to radiation and/or evaporation was taken into account implementing a previously developed model in the ANSYS code [6]. In the case of the Be armour, the melting was also considered in the calculation.

3. Thermal results

After the loss of a tile, the leading edge of the adjacent tile experiences a rapid increase of temperature. In the case of a Be armour melting occurs after 17 ms and the maximum temperature higher than 1800°C is reached in 150 ms. In the case of a CFC flat tile, the leading edge temperature exceeds 2000°C after 61 ms and reached the maximum value higher than 3000°C after about 1 s.

The armour-heat sink joint maximum temperature exceeds 800°C and approaches 500°C for a CFC and Be flat tile, respectively. Depending on the manufacturing technology, such high temperatures could have some deleterious effects on the joint. Furthermore the heat flux in the flat tile / heat sink joint experiences an increase of more than a factor of 2 and 6 for Be and CFC armours, respectively.

4. Erosion rate

The erosion rate of the armour material was computed by means of the model developed by Klippel and Van der Stad [7]. Fig. 3 shows the results obtained. Erosion rates as high as 1.23 and 0.36 mm/s were computed after 1 s for Be and CFC armours, respectively.

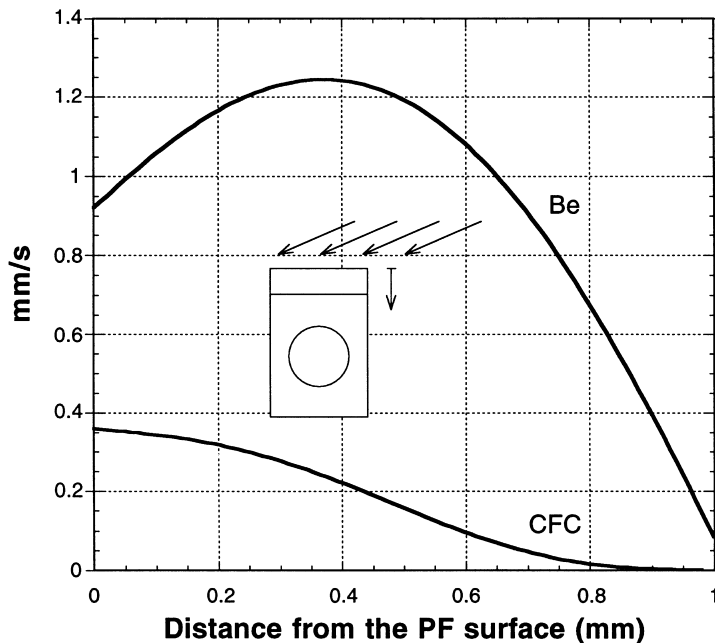

Fig. 3. Erosion rate of the adjacent tile 1 s after a tile falls off.

The highest erosion rate for Be occurs on the side surface 0.3–0.4 mm below the plasma facing surface. In fact, because of the considerable amount of power re-emitted mainly by evaporation cooling, the highest temperature is not reached on the plasma facing surface.

5. Critical heat flux

The evolution of the heat flux to the coolant after the loss of a tile was analysed. Fig. 4 shows the results obtained. An increase of about a factor 1.7 and 2.3 occurs for a Be and CFC tile, respectively. The lower increase in the case of a Be armour is due to a considerable amount of power re-emitted by evaporation. One can remember that these figures were computed assuming a starting incident heat flux of 5 MW/m^2 . A higher incident heat flux leads to higher values than those shown in Fig. 4. The increase of the heat flux to the coolant is less than linear with the incident heat flux due to a corresponding increase of the re-emitted power from the heated surface. However, the dramatic increase of the heat flux to the coolant may exceed the critical heat flux value causing the burnout of the component.

6. Thermal stress

A mechanical analysis of the transient following the loss of a tile was carried out in the case of a CFC armour

to study the thermal stress evolution in the adjacent unit. The generalised plane strain (bending constrained) modellistic approximation was adopted in the 2D elastic calculation. Fig. 5 shows the thermal stress in the copper alloy heat sink in the heat sink–armour joint. The Von Mises stress increases by a factor of 2 in less than 0.4 s and reaches extremely high values after 1 s. The stress component perpendicular to the joint (σ_y) doubles in less than 1 s and, being tensile, is likely to cause the tile detachment. A similar increase of the thermal stress occurs in the CFC tile in correspondence of the joint. Here the shear stress increases by more than a factor of 3 in about 1 s exceeding the value of 200 MPa. It is worth noting that CFC materials have the lowest strength in the shear direction.

7. Conclusions

The possibility to have a flat tile geometry for those high heat flux components subjected to a convective heat flux (namely the divertor dump target, lower vertical target, and the limiter) has been investigated. Beside the lower thermal fatigue lifetime when compared with a monoblock geometry, the main concerns regard the consequences of the loss of a tile on the adjacent unit. In fact, because of the glancing incidence of the power load, an extremely high heat flux hits the leading edge of the adjacent tile. As a result a rapid temperature rise occurs in the armour–heat sink joint which may seri-

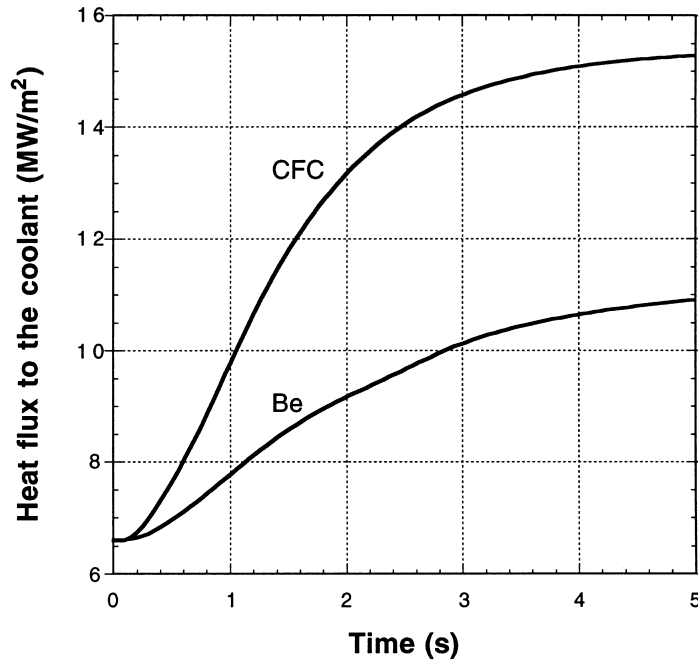

Fig. 4. Increase of the heat flux to the coolant in the adjacent unit after the loss of a tile. Starting incident heat flux 5 MW/m².

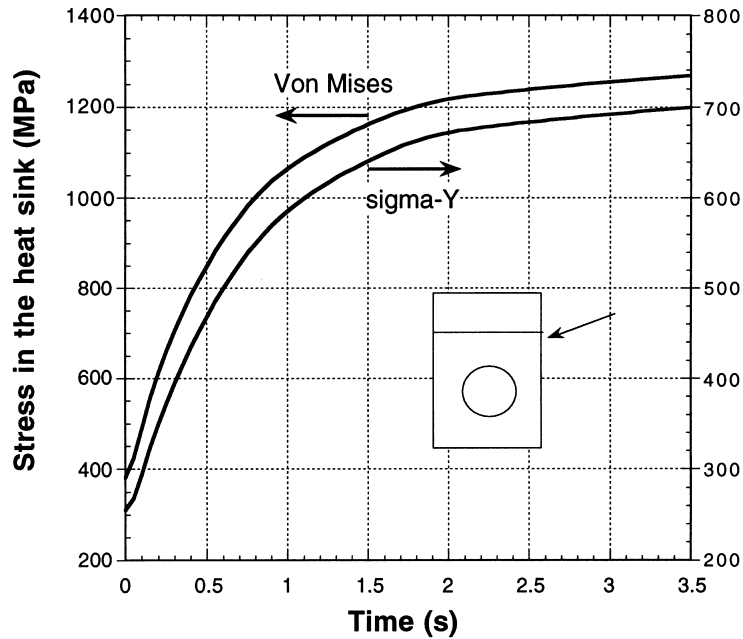

Fig. 5. Thermal stress vs. time in the copper alloy heat sink of the adjacent unit after the loss of a tile.

ously damage the joint, depending on the manufacturing technology. The heat flux to the coolant also increases rapidly up to a factor of 1.7 and 2.3 for a Be and CFC armour, respectively, thus causing possible critical heat flux problems. Thermal stresses in the armour–heat sink

joint double in less than 0.4 s and triplicate after 1 s thus leading to a possible cascade failure which could rapidly destroy several tiles if only one falls off.

The surface erosion, even if appreciable, is not rapid enough to smooth the heat flux on the leading edge

before the above-mentioned destroying phenomena take place. As a conclusion, all the above considerations strongly discourage the use of flat tile armour for those high heat flux components subjected to a convective heat flux. In this case a monoblock geometry gives a much more robust solution.

References

- [1] G. Vieider, V. Barabash, A. Cardella, P. Chappuis, R. Duwe, H. Falter, M. Febvre, L. Giancarli, C. Ibbott, D.M. Jacobson, R. Jakeman, G. Lemarois, A. Lind, M. Merola, H.D. Pacher, A. Peacock, A. Pizzuto, L. Plöchl, B. Riccardi, M. Rödiger, S.P.S. Sangha, Y. Severi, E. Visca, Overview of the EU small scale mock-up tests for ITER high heat flux components, Fourth International Symposium on Fusion Nuclear Technology, ISFNT-4, 6–11 April 1997, Tokyo.
- [2] R. Parker et al., Design and issues of the ITER in-vessel components, Fourth International Symposium on Fusion Nuclear Technology, ISFNT-4, 6–11 April 1997, Tokyo.
- [3] H.D. Pacher, Start-up power loads on ITER local adjustable limiters, NET Internal Note N/I/3340/3/A, Garching, Germany, February 1997.
- [4] ANSYS Finite Element Code, Release 5.3, October 1996.
- [5] M. Merola, G. Vieider, L. Schlosser, U. Mszanowski, I. Smid, EUPITER: the European Thermohydraulic Package for Plasma Facing Components, Proceedings of the Specialists' Workshop on High Heat Flux Cooling for ITER PFC's, JET, 23–25 September 1996.
- [6] Yu. Igitkhanov, H.D. Pacher, G. Federici, G. Janeschitz, D.E. Post, I. Smid, Effect of slow high-power transients on ITER divertor plates and limiter components, Proceedings of the 22nd EPS Conference on Controlled Fusion in Plasma Physics, Bournemouth, UK, July 1995.
- [7] H.Th. Klippel, R.C.L. Van der Stad, Thermal Analysis of Plasma Disruptions on First Wall and Divertor, Report ECN-C-90-003, Petten, December 1989.